

THE WEST AFRICAN EXAMINATIONS COUNCIL

West African Senior School Certificate Examination (WASSCE)  
for School Candidates

SC 2023

GENERAL MATHEMATICS / MATHEMATICS(CORE) 1

1½ hours

OBJECTIVE TEST

[50 marks]

Do not open this booklet until you are told to do so. While you are waiting, read and observe the following instructions carefully. Write your name and index number in the spaces provided above.

Answer all the questions on your Objective Test answer sheet.

- Use 2B pencil throughout.
- On the pre-printed answer sheet, check that the following details are correctly printed:
  - In the space marked *Name*, check your **surname** followed by your **other names**.
  - In the spaces marked *Examination*, *Year*, *Subject* and *Paper*, write 'WASSCE(SC)' '2023', 'GENERAL MATHEMATICS/MATHEMATICS (CORE)', and '1' respectively.
  - In the box marked *Index Number*, your **index number** has been printed vertically in the spaces on the left-hand side, and each numbered space has been shaded in line with each digit. **Reshade** each of the shaded spaces.
  - In the box marked *Subject Code*, the digits 402112 are printed vertically in the spaces on the left-hand side. **Reshade** the corresponding numbered spaces as you did for your index number.
- An example is given below. This is for a male candidate whose *name* is James Koku AMADU. His *index number* is 7102143958 and he is offering *Mathematics (Core) 1*.

THE WEST AFRICAN EXAMINATIONS COUNCIL  
ANSWER SHEET

PRINTED IN BLOCK LETTERS.	AMADU JAMES KOKU	GHA
Name:		
Examination:	WASSCE	Year: 2023
Subject:	MATHS(CORE)	Paper: 1

INSTRUCTIONS TO CANDIDATES

- Use grade 2B pencil throughout.
- Answer each question by choosing one letter and shading it like this:  A  B  C  D  E
- Erase completely any answer you wish to change.
- Leave extra spaces blank if the answer spaces provided are more than you need.
- Do not make any markings across the heavy black marks at the right hand edge of your answer sheet.

INDEX NUMBER		SUBJECT CODE	
7	0 1 2 3 4 5 6 7 8 9	4	0 1 2 3 4 5 6 7 8 9
1	0 1 2 3 4 5 6 7 8 9	0	0 1 2 3 4 5 6 7 8 9
0	0 1 2 3 4 5 6 7 8 9	2	0 1 2 3 4 5 6 7 8 9
2	0 1 2 3 4 5 6 7 8 9	1	0 1 2 3 4 5 6 7 8 9
1	0 1 2 3 4 5 6 7 8 9	1	0 1 2 3 4 5 6 7 8 9
4	0 1 2 3 4 5 6 7 8 9	2	0 1 2 3 4 5 6 7 8 9
3	0 1 2 3 4 5 6 7 8 9		
9	0 1 2 3 4 5 6 7 8 9		
5	0 1 2 3 4 5 6 7 8 9		
8	0 1 2 3 4 5 6 7 8 9		

For Supervisors only  
If candidate is absent shade this space.

Answer all the questions.

Mathematical tables may be used in any question. The use of non-programmable, silent and cordless calculator is allowed.

Each question is followed by four options lettered A to D. Find the correct option for each question and shade in pencil, on your answer sheet, the answer space which bears the same letter as the option you have chosen.

Give only one answer to each question. An example is given below.

The ages, in years, of four boys are 10, 12, 14 and 18. What is the average age of the boys?

- A. 12 years
- B.  $12\frac{1}{2}$  years
- C. 13 years
- D.  $13\frac{1}{2}$  years

The correct answer is  $13\frac{1}{2}$  years, which is lettered D, and therefore answer space D would be shaded.  A  B  C  D

Think carefully before you shade the answer spaces; erase completely any answers you wish to change.

Do all rough work on this question paper.

Now answer the following questions.

1. A point on the ground is 5 m away from the foot of a vertical wall 12 m high. Calculate, correct to the nearest degree, the angle of depression of the point from the top of the wall.
  - A.  $25^\circ$
  - B.  $23^\circ$
  - C.  $67^\circ$
  - D.  $65^\circ$
  
2. The gradient of the line passing through the points (3, 6) and (x, 4) is  $-\frac{2}{5}$ . Find the value of x.
  - A. 3
  - B. 8
  - C. 6
  - D. 5
  
3. A woman pours 85 litres of kerosene into a cylindrical container with radius 7 cm. Calculate, correct to the nearest cm, the depth of the kerosene in the container. [Take  $\pi = \frac{22}{7}$ ]
  - A. 240 cm
  - B. 552 cm
  - C. 480 cm
  - D. 595 cm

4. Given that  $x^2 - 11x + m$  is a perfect square, find the value of  $m$ .
- A.  $\frac{11}{2}$
- B.  $\frac{121}{8}$
- C.  $\frac{121}{4}$
- D. 121
5. The sides of a scalene triangle are 4 cm, 9 cm and 11cm. Calculate, correct to the nearest whole number, the area of the triangle.
- A.  $13 \text{ cm}^2$
- B.  $17 \text{ cm}^2$
- C.  $21 \text{ cm}^2$
- D.  $19 \text{ cm}^2$
6. In a hall, there are 175 persons. 12 % are children, 56 are men and the rest are women. If one person is selected at random from the hall, find the probability that a woman is selected.
- A.  $\frac{3}{25}$
- B.  $\frac{11}{25}$
- C.  $\frac{8}{25}$
- D.  $\frac{14}{25}$
7. A student measured the length of a classroom and obtained 3.99 m which is less than the actual length. If the percentage error was 5 %, what was the actual length?
- A. 3.80 m
- B. 3.78 m
- C. 4.18 m
- D. 4.20 m

8. A car covers the first 80 km of a journey in 2 hours and completes the journey by travelling further for 2.5 hours at 50 km/h. What is the average speed of the entire journey?

- A.  $44 \frac{4}{9}$  km/h  
 B.  $45 \frac{5}{9}$  km/h  
 C.  $47 \frac{1}{4}$  km/h  
 D.  $63 \frac{1}{4}$  km/h

9. If  $\log x = 2 - 3\log 2$ , find the value of  $x$ .

- A.  $\frac{5}{2}$   
 B.  $\frac{2}{5}$   
 C.  $\frac{2}{25}$   
 D.  $\frac{25}{2}$

10. The graph of  $y = x^2 - 5x + k$  passes through the point (3, 1). Find the value of  $k$ .

- A. 2  
 B. 3  
 C. 7  
 D. 5

- 11.

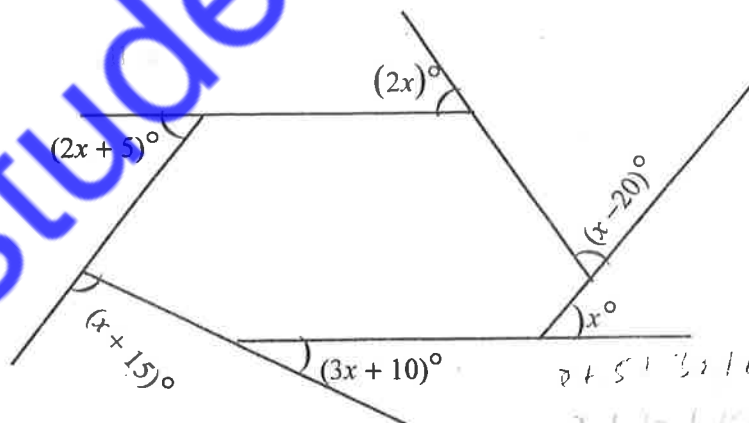

NOT DRAWN TO SCALE

Find the value of  $x$  in the diagram.

- A. 41  
 B. 37  
 C. 35  
 D. 31

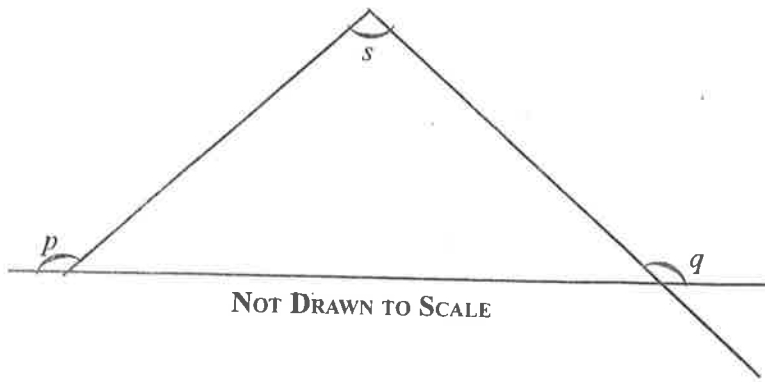

In the diagram,  $p + q = 250^\circ$ . Find the angle marked  $s$ .

- A.  $70^\circ$
- B.  $110^\circ$
- C.  $290^\circ$
- D.  $250^\circ$

13. If  $x : y : z = 2 : 3 : 4$ , evaluate  $\frac{9x + 3y}{6z - 2y}$ .

- A. 1.5
- B. 2.5
- C. 2.0
- D. 3.0

14. Find the mean of  $(x + y)$ ,  $(2x + 3y)$ ,  $(2x - 2y)$  and  $(3x - 2y)$ .

- A.  $4x$
- B.  $x$
- C.  $2x$
- D.  $3x$

15. A box contains 2 red, 6 white and 5 black balls, all of the same size. If a ball is selected at random, what is the probability that it is black?

- A.  $\frac{2}{13}$
- B.  $\frac{5}{11}$
- C.  $\frac{5}{13}$
- D.  $\frac{11}{13}$

16.

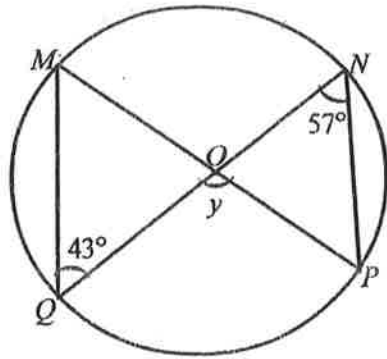

NOT DRAWN TO SCALE

In the diagram,  $MNPQ$  is a circle, centre  $O$ .  $\angle MQN = 43^\circ$  and  $\angle QNP = 57^\circ$ .  
Find the value of  $y$ .

- A.  $70^\circ$
- B.  $90^\circ$
- C.  $80^\circ$
- D.  $100^\circ$

17.

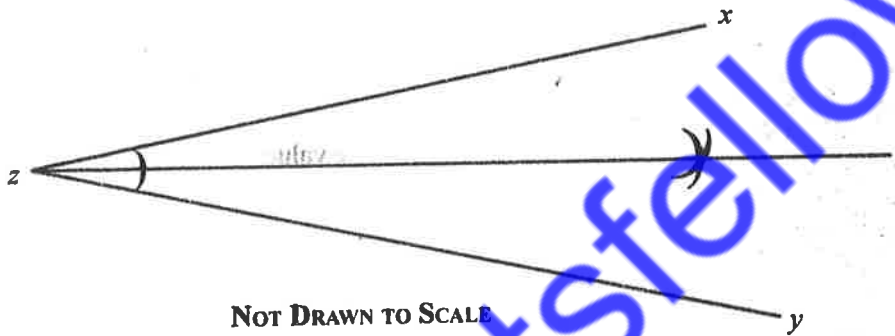

NOT DRAWN TO SCALE

Describe the locus,  $l$  in the diagram.

- A. Locus of points equidistant from  $x$  and  $z$ .
- B. Locus of points equidistant from  $x$  and  $y$ .
- C. Locus of points equidistant from  $xy$  and  $zy$ .
- D. Locus of points equidistant from  $zx$  and  $zy$ .

18. The base radius and slant height of a solid cone are 8 cm and 14 cm respectively. Calculate, correct to two decimal places, its volume. [Take  $\pi = \frac{22}{7}$ ]

- A.  $553.14 \text{ cm}^3$
- B.  $640.87 \text{ cm}^3$
- C.  $838.67 \text{ cm}^3$
- D.  $770.32 \text{ cm}^3$



19. Abudu can do a piece of work in 6 days and Efah can do the same work in 3 days. What fraction of the work can **both** do together in a day?

- A.  $\frac{1}{3}$   
 B.  $\frac{1}{8}$   
 C.  $\frac{2}{3}$   
 D.  $\frac{1}{2}$

20. If  $P = \{x: 1 \leq x \leq 6\}$  and  $Q = \{x: 2 < x < 9\}$  where  $x \in \mathbb{R}$ , find  $P \cap Q$ .

- A.  $\{x: 2 \leq x < 6\}$   
 B.  $\{x: 2 \leq x \leq 6\}$   
 C.  $\{x: 2 < x \leq 6\}$   
 D.  $\{x: 2 < x < 6\}$

21. Given that  $p^2 + q^2 + r^2 = 50$ ,  $p = 5$  and  $\sqrt{q} = 2$ , find the positive value of  $r$ .

- A. 5  
 B. 3  
 C. 4  
 D. 2

22. If  $\frac{1}{2}$  and  $-3$  are the roots of  $px^2 + qx + r = 0$ , find the values of  $p$ ,  $q$  and  $r$ .

- A.  $p = 2, q = -5, r = 3$   
 B.  $p = 2, q = 5, r = 3$   
 C.  $p = 2, q = 5, r = -3$   
 D.  $p = -2, q = 5, r = 3$

23. A cylindrical container closed at both ends has radius 5 cm and height 10 cm. Calculate, correct to two decimal places, the total surface area. [Take  $\pi = \frac{22}{7}$ ]

- A. 470.43 cm<sup>2</sup>  
 B. 471.43 cm<sup>2</sup>  
 C. 456.43 cm<sup>2</sup>  
 D. 460.43 cm<sup>2</sup>

24. Badu is four times as old as Juliet. In 10 years Badu will be twice as old as Juliet. Find Juliet's age.
- A. 3 years  
B. 6 years  
C. 5 years  
D. 8 years

25. When the point (4,5) is rotated through an angle in the anticlockwise direction about the origin, its image is (-5, 4). What is the angle of rotation?
- A.  $90^\circ$   
B.  $270^\circ$   
C.  $180^\circ$   
D.  $300^\circ$

26.

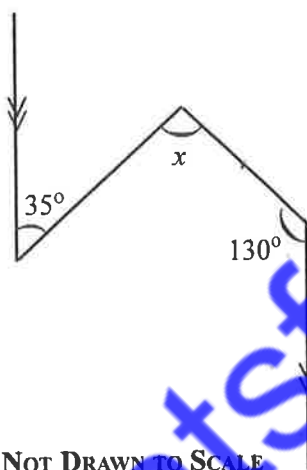

Find the value of  $x$  in the diagram.

- A.  $165^\circ$   
B.  $50^\circ$   
C.  $95^\circ$   
D.  $85^\circ$
27. A woman bought a washing machine for \$18,000.00. If the exchange rate is \$0.045 to ₦ 1.00, find in ₦, the cost of the machine.
- A. ₦ 400,000.00  
B. ₦ 600,000.00  
C. ₦ 250,000.00  
D. ₦ 300,000.00



28. Determine the least value of  $x$  such that  $7 + x = 3(\text{mod } 8)$ .
- A. 3  
B. 4  
C. 5  
D. 6
29. If  $\frac{4m + 3n}{4m - 3n} = \frac{5}{2}$ , find the ratio of  $m : n$ .
- A. 4 : 7  
B. 4 : 3  
C. 3 : 4  
D. 7 : 4
30. Yakubu received  $12\frac{1}{2}\%$  of the sales made in a certain month. If the amount he received was \$ 35,000.00, what was the total sales made?
- A. \$ 245,000.00  
B. \$ 140,000.00  
C. \$ 315,000.00  
D. \$ 280,000.00
31. The angle of elevation of the top of a vertical pole from a point, P on a level ground is  $60^\circ$ . The distance from P to the foot of the pole is 55 m. Find the height of the pole.
- A.  $\frac{55}{2}$  m  
B.  $55\sqrt{3}$  m  
C.  $\frac{55\sqrt{3}}{3}$  m  
D.  $\frac{55\sqrt{3}}{2}$  m
32. The ratio of girls to boys in a certain committee is 5 : 2. If there are 35 members in the committee, how many more boys must be added to the committee to have the ratio of girls to boys as 5 : 4?
- A. 20  
B. 10  
C. 15  
D. 5

33. Find the values of  $x$  for which  $\frac{x+1}{3x^2-12}$  is not defined.

- A.  $x = 2, -4$
- B.  $x = 4, -4$
- C.  $x = -2, 2$
- D.  $x = 0, 2$

34. Given that  $\tan x = \frac{12}{5}$ , find the value of  $(\sin x \cos x)$ .

- A.  $\frac{165}{60}$
- B.  $\frac{169}{65}$
- C.  $\frac{60}{169}$
- D.  $\frac{65}{169}$

35. Consider these two statements:

P:  $N$  is an odd number

Q:  $N$  is a prime number greater than 2.

Express "If  $N$  is not an odd number then  $N$  is not a prime number greater than 2" in symbolic form.

- A.  $\sim P \Rightarrow Q$
- B.  $\sim P \wedge \sim Q$
- C.  $P \Rightarrow \sim Q$
- D.  $\sim P \Rightarrow \sim Q$

36. A sector which subtends an angle  $150^\circ$  is cut from a circular plate of radius 14 cm. Find, correct to one decimal place, the perimeter of the remaining plate. [Take  $\pi = \frac{22}{7}$ ]

- A. 65.3 cm
- B. 79.3 cm
- C. 84.7 cm
- D. 64.7 cm

37. One side of a gutter is 15 cm lower than the other side. A plank of wood, which is laid across the gutter to form a bridge, slopes at an angle of  $35^\circ$  to the horizontal. How wide is the gutter?
- A. 18.31 cm
  - B. 21.42 cm
  - C. 26.15 cm
  - D. 10.50 cm

38.

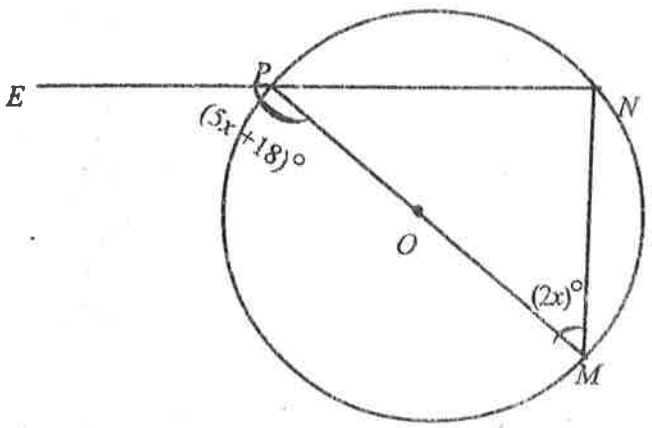

NOT DRAWN TO SCALE

In the diagram,  $MOP$  is the diameter of the circle  $MNP$  centre  $O$ ,  $\angle NMP = (2x)^\circ$  and  $\angle EPM = (5x + 18)^\circ$ . Find the value of  $x$ .

- A.  $72^\circ$
  - B.  $24^\circ$
  - C.  $48^\circ$
  - D.  $18^\circ$
39. The height of a square base pyramid is thrice the length of a side of its base. If the base area is  $324 \text{ cm}^2$ , find the volume of the pyramid.
- A.  $17,496 \text{ cm}^3$
  - B.  $5,832 \text{ cm}^3$
  - C.  $324 \text{ cm}^3$
  - D.  $972 \text{ cm}^3$
40. If  $4^x = \frac{1}{1024}$ , find the value of  $x$ .
- A. -10
  - B. -5
  - C. 8
  - D. 4

41.

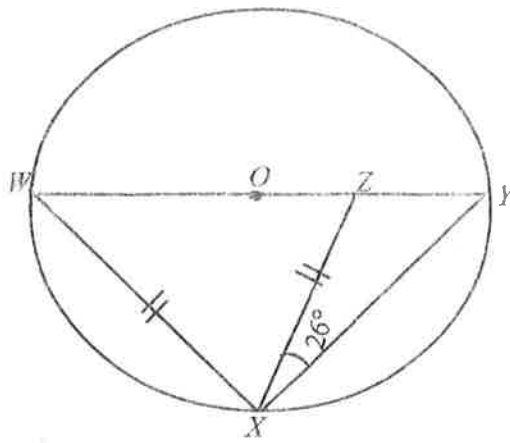

NOT DRAWN TO SCALE

In the diagram,  $O$  is the centre of the circle  $WXY$ .  $|WX| = |XZ|$  and  $\angle ZXY = 26^\circ$ . Find  $\angle XYZ$ .

- A.  $62^\circ$
- B.  $42^\circ$
- C.  $52^\circ$
- D.  $32^\circ$

42. Evaluate:  $141_{\text{six}} + 233_{\text{six}} - 102_{\text{six}}$

- A.  $412_{\text{six}}$
- B.  $405_{\text{six}}$
- C.  $312_{\text{six}}$
- D.  $305_{\text{six}}$

43. In the first year, Mr. Kwakye's annual salary was \$1,560.00. His salary was increased each year by a constant value,  $y$  until it was \$13,980.00 in the 13th year. Calculate the value of  $y$ .

- A. \$955.38
- B. \$1,230.00
- C. \$1,129.09
- D. \$1,035.00

$$15540 \div 13$$

44. Given that  $\frac{16}{9}, x, 1, y$  is a Geometric Progression (G.P), find the value of  $xy$ .

- A.  $\frac{9}{16}$
- B.  $\frac{25}{12}$
- C. 2
- D. 1

45. A chord of a circle, 12 cm long subtends an angle of  $150^\circ$  at the centre of the circle. Find the radius of the circle.

A. 3.0 cm  
 B. 4.3 cm  
 C. 6.0 cm  
 D. 6.2 cm

46. The lines  $3x + 2y = 4$  and  $y = 2x - 5$  intersect at a point  $P(x, y)$ . Find the coordinates of  $P$ .

A. (2, 1)  
 B. (-2, 1)  
 C. (2, -1)  
 D. (-2, -1)

47. Make  $u$  the subject of the relation  $\frac{t}{s+u} = \frac{s}{t-u}$ .

A.  $u = s - t$   
 B.  $u = t - s$   
 C.  $u = ts$   
 D.  $u = t + s$

Number of subjects	1	2	3	4	5	6	7	8
Number of students	2	1	4	3	8	5	4	3

The table shows the number of subjects registered by a class of students preparing for an examination.

Use the information to answer questions 48 and 49.

48. Calculate the mean of the distribution.

A. 2  
 B. 3  
 C. 8  
 D. 5

49. Find the median.

A. 2  
 B. 5  
 C. 3  
 D. 8

50. A rectangular tank of sides 4 m by 8 m by 11 m has the same volume as a cylindrical tank of height 7 m. Calculate the base radius of the cylindrical tank. [Take  $\pi = \frac{22}{7}$ ]
- A. 4 m  
B. 22 m  
C. 8 m  
D. 88 m

*END OF PAPER*

thestudentstofellow.com



SC40225

WASSCE 2023

GENERAL MATHEMATICS/  
MATHEMATICS (CORE) 2

2½ hours

2

Name.....

Index Number.....

THE WEST AFRICAN EXAMINATIONS COUNCIL

West African Senior School Certificate Examination  
for School Candidates

SC 2023

GENERAL MATHEMATICS/MATHEMATICS (CORE) 2  
[100 marks]

2½ hours

Write your name and index number in ink in the spaces provided above.

Answer ten questions in all. All the questions in Section A and five questions from Section B.

In each question, all necessary details of working, including rough work, must be shown with the answer.

Give answers as accurately as data and tables allow.

Graph papers are provided for your use in the examination.

The use of non-programmable, silent and cordless calculator is allowed.

SECTION A  
[40 marks]

Answer **all** the questions in this section. All questions carry **equal** marks.

1. In a talent hunt competition of 35 artistes, they indicated their interest in playing Cymbal, Saxophone, and Bongo. Out of the number, 24 preferred Cymbal, 16 Saxophone and 18 Bongo. 8 preferred Cymbal only, 2 Saxophone only and 6 Bongo only. 4 played all the three instruments while 7 preferred Cymbal and Saxophone only.

- (a) Illustrate the information in a Venn diagram.
- (b) Find the number of artistes who preferred:
- only** two types of instruments;
  - only** one type of instrument.

$$\begin{aligned}
 &N = 35 \text{ artistes} \\
 &C(S) = 24 \\
 &S(S) = 16 \\
 &C(B) = 18 \\
 &8(C) \text{ only} = 8 \\
 &2(S) \text{ only} = 2 \\
 &6(B) \text{ only} = 6
 \end{aligned}$$

2. Doris walked  $2t$  km from a village, K to visit a friend in another village, L on a bearing of  $065^\circ$ . After spending some time with her friend, she continued to a nearby town, M,

$3t$  km away on a bearing of  $155^\circ$ . If the distance between K and M is  $6\sqrt{13}$  km:

- (a) illustrate the information in a diagram;
- (b) calculate, correct to the **nearest** whole number, the
- value of  $t$ ;
  - bearing of M from K.
3. In the frustrum of a cone, the bottom diameter is **thrice** the top diameter.
- (a) If the height of the frustrum is 12 cm, calculate the height of the whole cone.
- (b) Given that the volume of the whole cone is  $39,600 \text{ cm}^3$ , find, correct to **four** significant figures, the radius. [Take  $\pi = \frac{22}{7}$ ]

4.

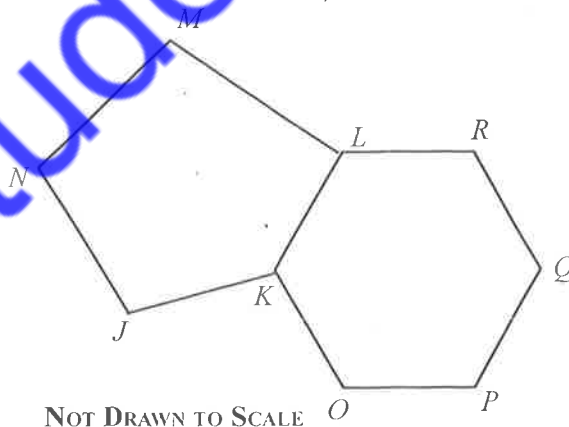

In the diagram,  $JKLMN$  is a regular pentagon and  $KOPQLR$  is a regular hexagon. Find:

- $\angle JNM$ ;
- $\angle KOP$ ;
- $\angle MLR$ .

5. The mean age of a second year class of a school is  $18\frac{2}{5}$ . At the end of the promotion examination, 3 students aged 20, 19 and 19 years were repeated. The new mean age of the class became  $18\frac{1}{3}$ . Calculate the number of students who were in the class before the promotion examination.

## SECTION B

[60 marks]

Answer **five** questions **only** from this section. All questions carry equal marks.

6. (a) In a certain spider web, the lengths of the shortest and longest threads are 3.4 mm and 50.2 mm respectively. The successive equally spaced threads are 1.2 mm apart. If the length of the cross threads form an Arithmetic Progression (A.P), find the number of cross threads.
- (b) At noon, a cargo plane leaves Moi airport and heads towards Kisumu 500 km away at 180 km/h. At 1.00 pm, a jet takes off from Moi and flies on the same course at 450 km/h. What time will the jet overtake the cargo plane?
7. A man left an estate for his wife, extended family and children; Dakorah, Gifty and Gemma. In the will,  $\frac{1}{3}$  of the estate must be given to Dakorah,  $\frac{1}{3}$  of the remaining to Gifty,  $\frac{3}{4}$  of what still remains to Gemma,  $\frac{2}{3}$  of the remaining to the wife and the rest to the extended family. If the wife received a total of GH¢ 105,500.00 as her share of the estate, find the:
- (a) total value of the estate;
- (b) extended family's share of the estate.

8.

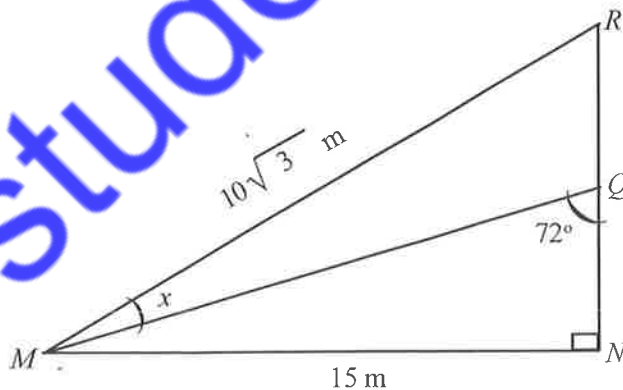

NOT DRAWN TO SCALE

In the diagram,  $MNR$  is right angle triangle.  $|MN| = 15 \text{ m}$ ,  $|MR| = 10\sqrt{3} \text{ m}$  and  $\angle MQR = 72^\circ$ . Calculate, correct to the **nearest** whole number:

- (a) the value of the angle marked  $x$ ;
- (b)  $|QR|$ ;
- (c) area of  $\triangle MQR$ .

9.

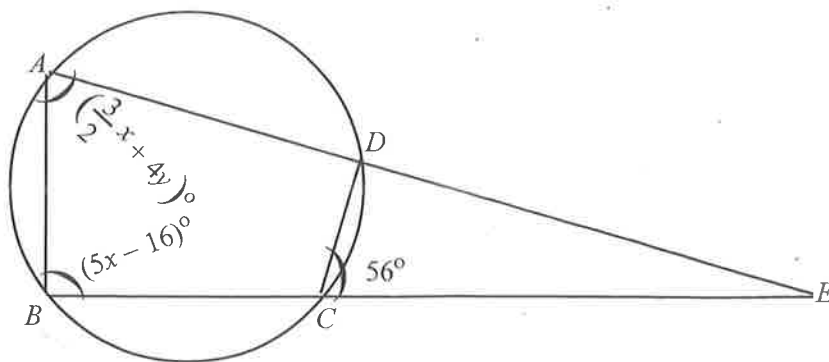

NOT DRAWN TO SCALE

In the diagram, A, B, C, D are points on a circle. ADE and BCE are straight lines.

$\angle DCE = 56^\circ$ ,  $\angle ABE = (5x - 16)^\circ$  and  $\angle BAE = \left(\frac{3}{2}x + 4y\right)^\circ$ . If  $\angle DCE : \angle CDE = 7:8$ ;

find:

- $\angle AEB$ ;
- the values of  $x$  and  $y$ .

10.

- A cupboard contains three kinds of notebooks:  $J$ ,  $K$  and  $L$ , all of the same size. The number of book  $J$  is 3 more than **half** of book  $L$ . The number of  $K$  is **one-third** the number of  $L$ .

- If there are 25 books in the cupboard, find the number of **each** kind of book.
- If a book is picked at random from the cupboard, what is the probability that it is  $K$  or  $L$ ?

(b)

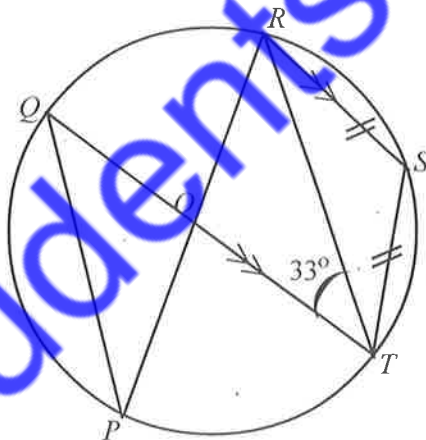

NOT DRAWN TO SCALE

In the diagram  $PQRST$  is a circle with centre  $O$ .  $POR$  and  $QOT$  are straight lines,  $\overline{QT} \parallel \overline{RS}$ ,  $\angle RTQ = 33^\circ$  and  $|\overline{RS}| = |\overline{ST}|$ . Find  $\angle RST$ .

11. (a) From the top,  $X$  of a building 320 m high, the angles of depression of the top,  $Y$  and bottom,  $Z$  of another building on the same horizontal ground are  $29^\circ$  and  $41^\circ$  respectively.
- Illustrate the information in a diagram.
  - Calculate, correct to the nearest metre, the height of the other building.

- (b) The time taken to travel a distance of 120 km was reduced by 30 minutes when the speed was increased by 20 km/h. Calculate the initial speed.

12. (a) The following statements are true of a certain community.

$S$ : Most businessmen are rich.

$T$ : No salary worker is rich.

- Draw a Venn diagram to illustrate the information.
- State whether the following statements are **Valid** or **Not Valid**.
  - Ali is a businessman and is therefore rich.
  - Ahmed is **not** rich because he is a salary worker.

- (b)

Heights (cm)	60 — 64	65 — 69	70 — 74	75 — 79	80 — 84
Frequency	7	6	5	8	4

The table shows the distribution of height of seedlings in a nursery. Calculate, correct to one decimal place, the:

- mean;
- variance of the distribution.

13. (a) Using a scale of 2 cm to 1 unit on both axes, draw on a graph sheet two perpendicular axes  $ox$  and  $oy$  for  $0 \leq x \leq 8$  and  $-6 \leq y \leq 6$ .

- Plot the points  $M(3, 1)$ ,  $N(1, 1)$  and  $P(3, 5)$ . Join the points to get  $\triangle MNP$ .
- Draw image triangle  $M_1N_1P_1$  which is the reflection of  $\triangle MNP$  in the  $x$ -axis where  $M \rightarrow M_1$ ,  $N \rightarrow N_1$  and  $P \rightarrow P_1$ . Indicate clearly the coordinates of  $M_1$ ,  $N_1$  and  $P_1$ .
- Draw the image triangle  $M_2N_2P_2$  which is the image of  $\triangle MNP$  under

the mapping  $\begin{pmatrix} x \\ y \end{pmatrix} \rightarrow \begin{pmatrix} 2x \\ -y \end{pmatrix}$ , where  $M \rightarrow M_2$ ,  $N \rightarrow N_2$  and  $P \rightarrow P_2$ .

Indicate clearly the coordinates of  $M_2$ ,  $N_2$  and  $P_2$ .

- (b) Find the equation of the line joining the points  $M$  and  $M_2$ .

**END OF PAPER**